

HB600GKFaPo



Only have limited space?

Then the HB600GKFaPo, the shortest counterweight crane, may be of interest to you. It has a wheelbase of just 1000 mm! It only requires a turning radius of approx. 1600 mm, with approx. 2000 mm in front of the wheels still 200 kg capacity.

At a glance

LIFTING	
manual	✓
Compact hydraulic system	✗
Hydrobull pump	✓
electric	✗

DRIVING	
manual	✓
Steering handle	✗
FaPo	✓
electric	✗

OPERATING FREQUENCY	
up to 10 times per month	✗
up to 25 times per month	✗
up to 100 times per month	✓
more than 100 times per month	✗

LIFTING CAPACITY WITH HORIZONTAL JIB		
	max. 600 kg in front of the wheels	✓
	180 kg at 2530 mm in front of the wheels	✓

Link to www.hydrobull.de

Here, you can find more information incl. videos, photos etc.



This original Hydrobull crane with counterweight have a rear-mounted chassis and a counterweight box. The counterweight allows it to directly approach loads and machines. The machines can be placed on full-length platforms or be very wide. All 13 positions are **in front of the wheels**, so the crane has an extremely clear outreach. The clear outreach and the large lifting height allow the cranes to be used frequently for tool changes and maintenance work (also above machine installations or under the ceiling). The counterweight crane was designed to provide a long service life even with frequent use.

🔸 LIFTING/LOWERING



Secured to a high-quality galvanised DIN-standard swivel hook with the original **Hydrobull pump with 4 power/lift settings**. The detailed description can be found in our Technical Information Sheet 1.

🔸 Driving



Manually supported by the Hydrobull mechanical **driving positioning device, FaPo®** for short. The detailed description can be found in our Technical Information Sheet 1.

🔸 JIB

Has 13 setting which can be easily selected via 2two separate galvanized jibs using a socket pin system. In addition, the jibs are secured with a squeeze-out lock to prevent accidents due to unintentional falling out.

🔸 PARKING

Is done easily and conveniently by turning a lever mounted on the guard of the FaPo steering wheel. **Manual machines are generally** not equipped with a travel brake.

🔸 COUNTERWEIGHT

ATTENTION!

Only use with filled box!
You can fill the box with steel plates yourself.



The empty counterweight box is supplied fitted on the crane and is removable. On the right and left side are openings for attaching suitable lifting aids. After filling, these openings can be closed with the plastic caps supplied, so that no weight is lost. The counterweight box also has a lid for closing. The lid has a device that allows you to lock it with a customer-supplied padlock. On request, we can fill the counterweight box for an additional charge. It is delivered as a separate package on a pallet and must be placed on the crane by you using suitable lifting equipment.

🔸 OTHER

- Seal kits and other spare parts are available ex stock for both the cylinder and the pump
- Modern, protected design – only from Hydrobull
- Delivery incl. inspection book and operating instructions
- German Product
- Euronorm 2006/42/EC and DGUV68
- **2 Year Warranty**
- Spare parts for older machines on request

Technical Drawings

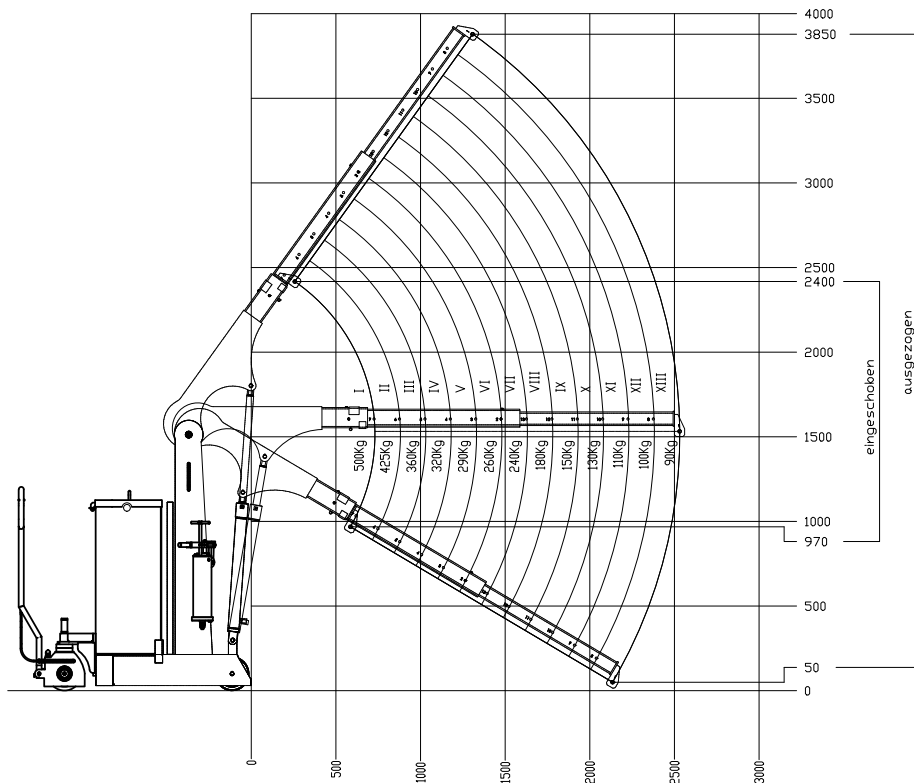
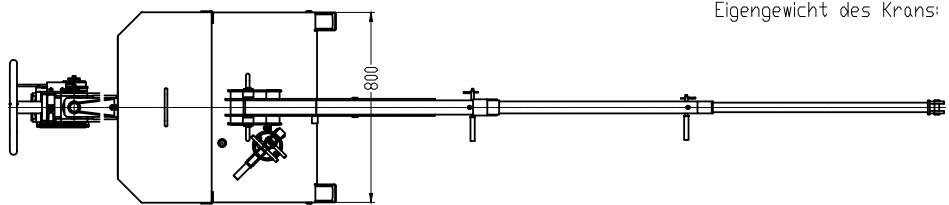
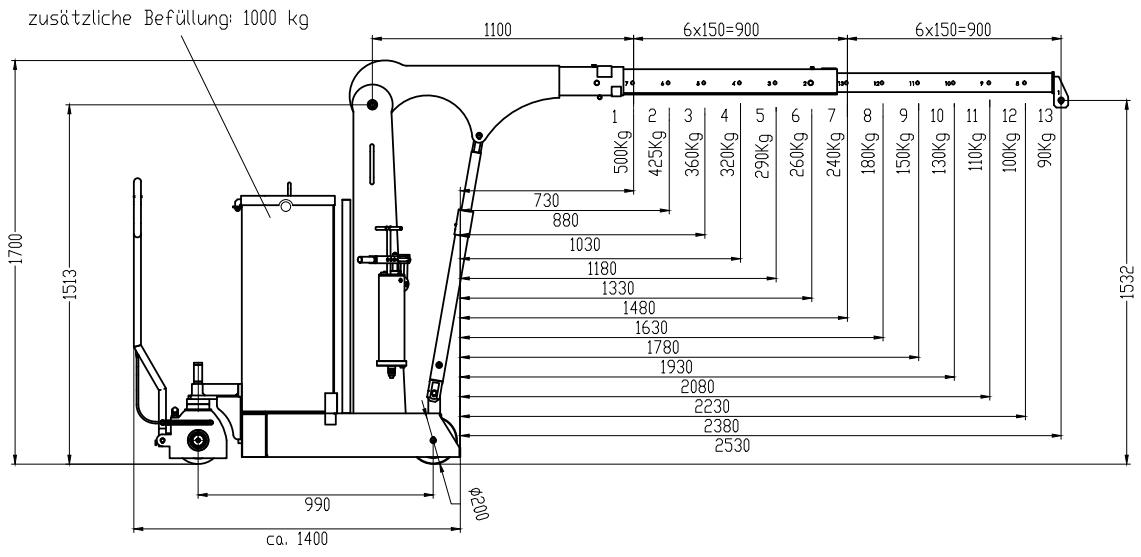

Subject to technical modifications. Data subject to manufacturing tolerances.

Technical specifications

RATIO LIFTING CAPACITY, OUTREACH, LIFTING HEIGHT					
Jib	Lifting capacity/kg	Load with horizontal jib/mm		Lift height*/mm	
Position		in front of the hydraulic system approx.	in front of the wheels approx.	min.	max.
1	600	630	730	780	2240
2	500	780	880	700	2360
3	450	930	1030	620	2480
4	390	1080	1180	540	2600
5	350	1230	1330	465	2720
6	300	1380	1480	390	2840
7	290	1530	1630	320	2960
8	250	1680	1780	245	3080
9	240	1830	1930	170	3200
10	230	1980	2080	100	3320
11	210	2130	2230	30	3440
12	200	2280	2380	0	3560
13	180	2430	2530	0	3680

* at hook mouth opening - please refer to the diagram for the reduced outreach

OTHER DETAILS		min.	max.
Jib length from... to...		1100	2900
Length of wheelbase	mm		990
Length of chassis incl. wheels	mm		1400
Length incl. inserted lowered jib Pos. 1	mm		2000
approx. aisle width for 90° turn	mm		1600
Width of chassis external	mm		800
Width of chassis internal	mm		-
Clearance height, jib horizontal	mm		1700
Clearance height, jib lowered	mm		1670
Clearance	mm		-
Hook length approx.	mm		225
Ground clearance	mm		30
Load wheel	mm		200
Steering wheel	mm		200
Slewing			-
Tare weight - for counterweight cranes incl. empty box	kg		360
Required filling weight for counterweight cranes**	kg		1200
Batteries			-

** Machine can only be used when installed



Not the right machine? No problem!

Fill out our form on www.hydrobull.de and we will happily produce a custom transport solution for you.